



US 20050194890A1

(19) **United States**

(12) **Patent Application Publication** (10) **Pub. No.: US 2005/0194890 A1**

**Koo et al.**

(43) **Pub. Date:**

**Sep. 8, 2005**

(54) **ORGANIC ELECTROLUMINESCENT DISPLAY AND METHOD OF MANUFACTURING THE SAME**

**Publication Classification**

(51) **Int. Cl.<sup>7</sup>** ..... **H05B 33/00**; H01J 9/00; H05B 33/14; H05B 33/10  
(52) **U.S. Cl.** ..... **313/503**; 313/506; 313/504; 445/24

(75) Inventors: **Jae-Bon Koo**, Yongin-city (KR); **Sang-Il Park**, Seoul (KR)

Correspondence Address:  
**STEIN, MCEWEN & BUI, LLP**  
**1400 EYE STREET, NW**  
**SUITE 300**  
**WASHINGTON, DC 20005 (US)**

(57) **ABSTRACT**

An organic electroluminescent display and a method of manufacturing the same are provided. The organic electroluminescent display includes a substrate, at least a thin-film transistor, which is formed on the substrate, at least an insulation layer, which cover the thin-film transistor, first electrodes, which are formed in a predetermined pattern on a top surface of the insulation layer and to which a voltage is selectively applied through the thin-film transistor, bus electrodes, which are insulated from the first electrodes, a planarization layer, which is an insulation layer and has openings exposing the first electrodes and the bus electrodes, organic layers, which are formed on a top surface of the first electrodes, and second electrodes, which are formed on a top surface of the planarization layer and are electrically connected to the bus electrodes.

(73) Assignee: **SAMSUNG SDI CO., LTD.**, Suwon-si (KR)

(21) Appl. No.: **11/116,219**

(22) Filed: **Apr. 28, 2005**

**Related U.S. Application Data**

(63) Continuation of application No. 10/663,800, filed on Sep. 17, 2003, now Pat. No. 6,917,160.

(30) **Foreign Application Priority Data**

Sep. 19, 2002 (KR) ..... 2002-57336

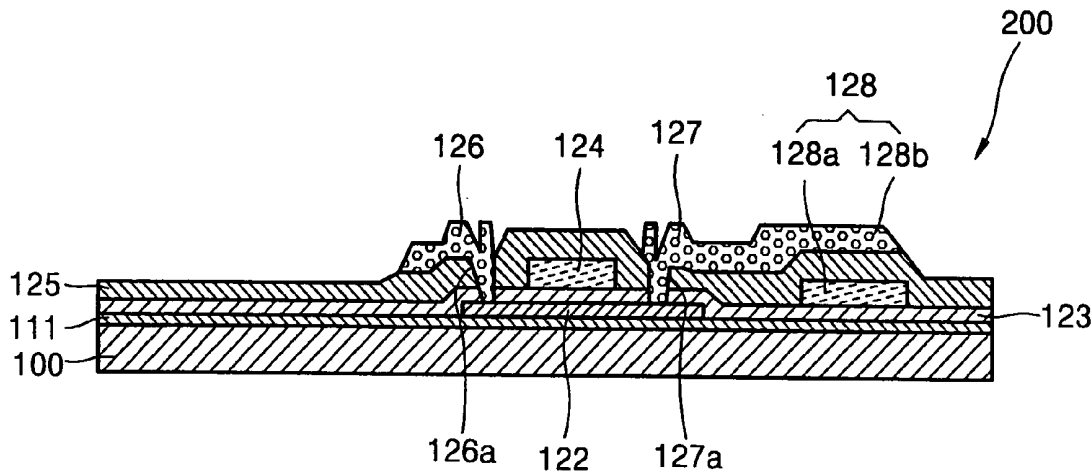

FIG. 1

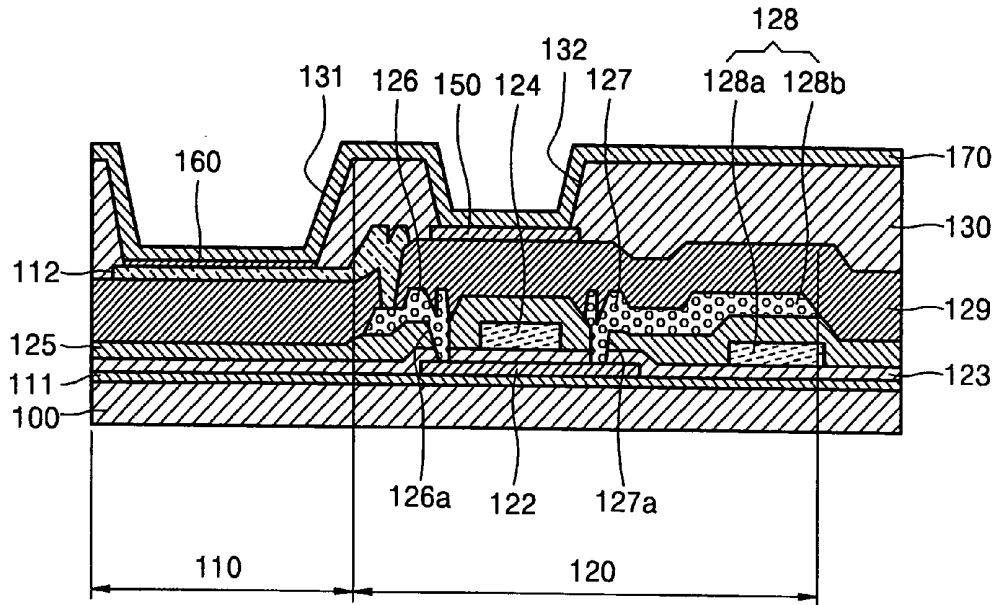

FIG. 2

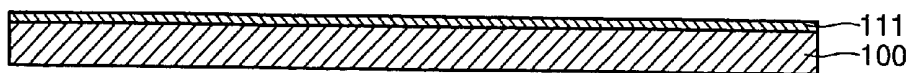

FIG. 3

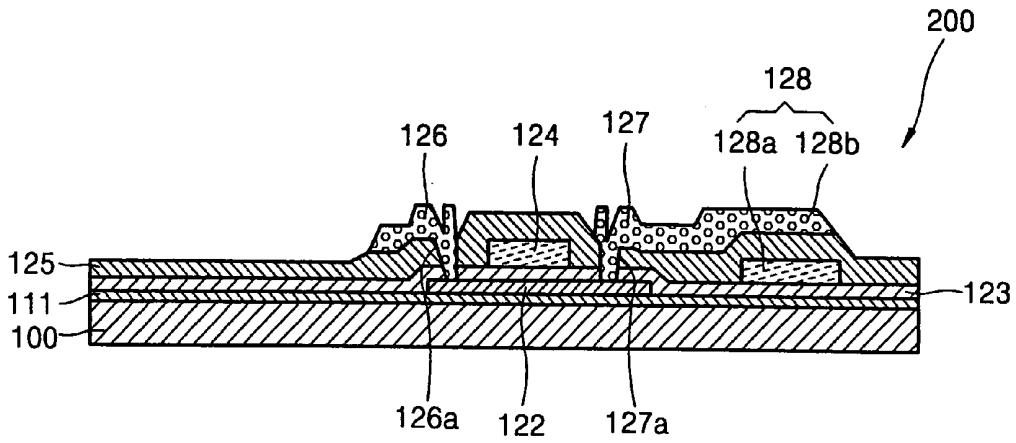

FIG. 4

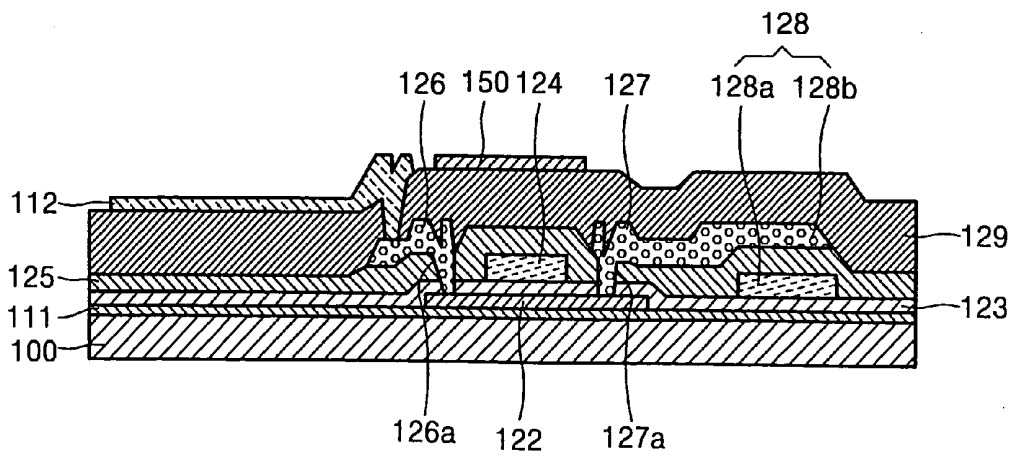

FIG. 5

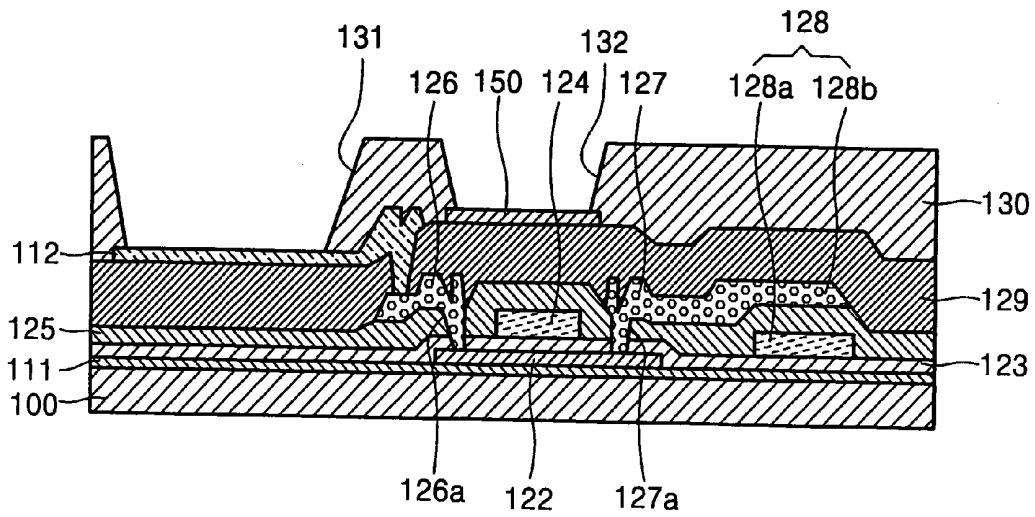

FIG. 6

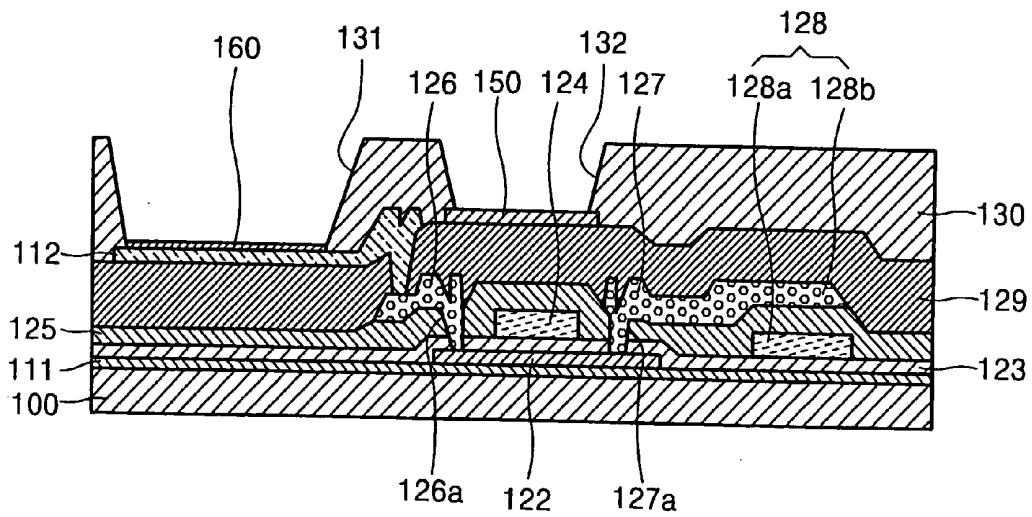
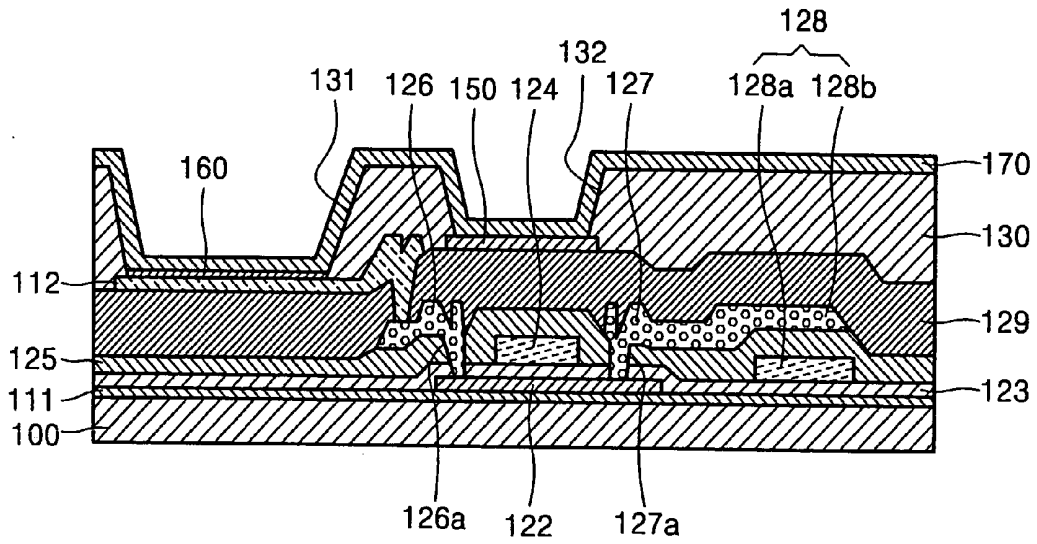

FIG. 7



**ORGANIC ELECTROLUMINESCENT DISPLAY  
AND METHOD OF MANUFACTURING THE SAME****CROSS-REFERENCE TO RELATED  
APPLICATIONS**

[0001] This application is a continuation of Ser. No. 10/663,800 filed Sep. 17, 2003, now allowed, and claims the priority of Korean Patent Application No. 2002-57336, filed on Sep. 19, 2002, in the Korean Intellectual Property Office, the disclosure of which is incorporated herein by reference.

**BACKGROUND OF THE INVENTION****[0002] 1. Field of the Invention**

[0003] The present invention relates to an organic electroluminescent display, and more particularly, to an organic electroluminescent display with an improved electrode structure.

**[0004] 2. Description of the Related Art**

[0005] Generally, organic electroluminescent displays are self-luminescent displays which emit light by electrically exciting a fluorescent organic compound. They can be operated with low voltage and can be made thin. In addition, organic electroluminescent displays have advantages, such as a wide viewing angle and a fast response speed, that overcome the problems of liquid crystal displays. Accordingly, they have been noted as next generation displays.

[0006] In such organic electroluminescent displays, an organic layer is formed in a predetermined pattern on a substrate made of glass or other transparent materials, and electrode layers are disposed under and below the organic layers.

[0007] In organic electroluminescent displays having the above-described structure, when positive and negative voltages are applied to the electrodes, holes are moved from an electrode, to which a positive voltage is applied, to a luminescent layer via a hole transport layer. Electrons are moved from an electrode, to which a negative voltage is applied, to the luminescent layer via an electron transport layer. The electrons meet the holes in the luminescent layer, thereby generating excitons. The excitons make transitions from an excitation state to a ground state, thereby provoking fluorescent molecules of the luminescent layer to emit light. As a result, an image is formed.

[0008] The light efficiency of organic electroluminescent displays operating as described above is divided into internal efficiency and external efficiency. The internal efficiency depends on the photoelectric conversion efficiency of an organic luminescent material. The external efficiency is referred to as light coupling efficiency and depends on the refractivity of each of layers included in an organic electroluminescent display. Organic electroluminescent displays have lower external efficiency than other displays such as cathode-ray tubes and plasma display panels (PDPs). Accordingly, such organic electroluminescent displays need to be improved in terms of characteristics of displays, such as brightness and a life span.

[0009] In the meantime, in organic electroluminescent displays having the above-described structure, as the size of a panel increases, the line resistance of an electrode increases, which causes the brightness of an image to be

nonuniform. In particular, when an organic electroluminescent display is driven by a thin-film transistor, the line resistance of a cathode increases, and thus the above problem occurs.

[0010] Japanese Patent Publication Nos. sho 62-172691, sho 63-172691, hei 1-220394, and hei 11-283751 disclose conventional organic electroluminescent displays. These conventional organic electroluminescent displays are not provided with an element for reducing the line resistance of a cathode and thus still have a problem of nonuniform brightness of an image due to the line resistance.

**SUMMARY OF THE INVENTION**

[0011] The present invention provides an organic electroluminescent display for reducing the line resistance of an electrode so that the brightness of an image can be prevented from being nonuniform due to the line resistance.

[0012] The present invention also provides an organic electroluminescent display, in which a bus electrode for reducing the line resistance of a cathode is formed in a simple structure, thereby reducing manufacturing cost.

[0013] According to an aspect of the present invention, there is provided an organic electroluminescent display comprising a substrate, at least a thin-film transistor, which is formed on the substrate, at least an insulation layer, which cover the thin-film transistor, first electrodes, which are formed in a predetermined pattern on a top surface of the insulation layer and to which a voltage is selectively applied through the thin-film transistor, bus electrodes, which are insulated from the first electrodes, a planarization layer, which is an insulation layer and has openings exposing the first electrodes and the bus electrodes, organic layers, which are formed on a top surface of the first electrodes, and second electrodes, which are formed on a top surface of the organic layer and a top surface of the planarization layer and are electrically connected to the bus electrodes. The second electrodes are made of a transparent material. Thus, the organic electroluminescent display is very effective when the second electrodes are applied to a structure in which light is discharged through a front side. The first electrodes and the bus electrodes are made of the same material. The bus electrodes are formed on a top surface of the insulation layer. Light emitted from the organic layers may be discharged in a direction of the second electrodes

[0014] According to another aspect of the present invention, there is also provided a method of manufacturing an organic electroluminescent display, the method comprising, forming at least a thin-film transistor on a top surface of a substrate, forming at least an insulation layer on a top surface of the thin-film transistor, forming first electrodes, to which a potential is selectively applied through the thin-film transistor, and bus electrodes, which are electrically insulated from the first electrodes on a top surface of the insulation layer, forming a planarization layer on a top surface of the insulation layer to have openings at positions corresponding to the first electrodes and the bus electrodes, forming organic layers on a top surface of the first electrodes, and forming second electrodes on a top surface of the planarization layer and a top surface of selected organic layers and are electrically connected to the bus electrodes.

## BRIEF DESCRIPTION OF THE DRAWINGS

[0015] The above and other features and advantages of the present invention will become more apparent by describing in detail preferred embodiments thereof with reference to the attached drawings in which:

[0016] **FIG. 1** is a cross-section of an organic electroluminescent display according to an embodiment of the present invention; and

[0017] **FIGS. 2 through 7** are cross-sections of stages in a method of manufacturing an organic electroluminescent display according to an embodiment of the present invention.

## DETAILED DESCRIPTION OF THE INVENTION

[0018] Reference will now be made in detail to the embodiments of the present invention, examples of which are illustrated in the accompanying drawings, wherein like reference numerals refer to the like elements throughout. The embodiments are described below in order to explain the present invention by referring to the figures.

[0019] **FIG. 1** shows an example of an active matrix organic light emitting display (AMOLED), as an organic electroluminescent display according to an embodiment of the present invention. Referring to **FIG. 1**, a buffer layer **111** is formed on a top surface of a transparent substrate **100**. The organic electroluminescent display shown in **FIG. 1** is largely divided into a pixel formation section **110**, which includes a first electrode **112** for forming a pixel above the buffer layer **111**, and a driving section **120**, which drive electrodes of the pixel formation section **110** using thin-film transistors (TFTs) and capacitors.

[0020] The driving section **120** includes TFTs and capacitors, which are formed on the buffer **111**. The TFT includes a P or N type semiconductor layer **122**, which is formed in a predetermined pattern on a top surface of the buffer **111**; a gate insulation layer, i.e., a first insulation layer **123**, which covers the semiconductor layer **122**; a gate electrode layer **124**, which is formed on a top surface of the first insulation layer **123** so as to correspond to the semiconductor layer **122**; a second insulation layer **125**, which covers the gate electrode layer **124**; and a drain electrode **126** and a source electrode **127**, which are formed on the second insulation layer **125** and respectively connected to both ends of the semiconductor layer **122** through contact holes **126a** and **127a** penetrating the second insulation layer **125** and the first insulation layer **123**. The capacitor **128** includes a first auxiliary electrode **128b**, which are formed on a top surface of the second insulation layer **125** and connected to the source electrode **127**, and a second auxiliary electrode **128a**, which is covered with the second insulation layer **125** so as to correspond to the first auxiliary electrode **128b**. A third insulation layer **129** is formed on a top surface of the second insulation layer **125** to cover the drain electrode **126** and the source electrode **127**.

[0021] Here, the shapes of the first, second, and third insulation layers **123**, **125**, and **129** can vary with a state of the TFT. In addition, the number of the first, second, and third insulation layers **123**, **125**, and **129** can be reduced, and they are made of a transparent material. And numbers of the TFT and the capacitor may be varied.

[0022] In the meantime, the pixel formation section **110** includes the first electrode **112**, which is formed on a top surface of the third insulation layer **129** stacked on the transparent substrate **100** and is electrically connected to the drain electrode **126**. A bus electrode **150** is formed in a predetermined pattern on a top surface of the third insulation layer **129** to be electrically insulated from the first electrode **112**.

[0023] A planarization layer **130**, i.e., a fourth insulation layer, is formed on an entire surface of the third insulation layer **129** on which the first electrode **112** and the bus electrode **150** are formed. The planarization layer **130** has a first opening **131**, which exposes a part of the first electrode **112**, and a second opening **132**, which exposes a part of the bus electrode **150**. An organic layer **160** is formed on a top surface of the first electrode **112** exposed through the first opening **131**. A second electrode **170** is formed on the organic layer **160** and the planarization layer **130** to be electrically connected to the bus electrode **150**. Here, the first electrode **112** and the bus electrode **150** are made of the same material. It is preferable that the bus electrode **150** is formed in a predetermined pattern so as to reduce the line resistance of the second electrode **170**.

[0024] In an organic electroluminescent display having the above-described structure according to the present invention, when a predetermined voltage is applied to the first electrode **112** through the driving section **120**, a voltage is applied to the second electrode **170**. Then, holes move from the first electrode **112** to a luminescent layer of the organic layer **160**, and electrons move from the second electrode **170** to the luminescent layer. The electrons meet the holes in the luminescent layer, thereby generating excitons. The excitons make transitions from an excitation state to a ground state, thereby provoking fluorescent molecules of the luminescent layer to emit light. The emitted light is discharged through a front side (when the second electrode **170** is made of a transparent material) or a rear side.

[0025] In the above-described procedure, since the second electrode **170** is electrically connected to the bus electrode **150** having a predetermined pattern, current and voltage flowing through the second electrode **170** can be prevented from dropping. Due to this prevention of the drop of voltage and current, current and voltage for exciting the organic layer **160** positioned between the first and second electrodes **112** and **170** can be maintained constant. As a result, the brightness of an image can be fundamentally prevented from being nonuniform throughout the image.

[0026] **FIGS. 2 through 7** are cross-sections of stages in a method of manufacturing an organic electroluminescent display having the above-described structure, according to an embodiment of the present invention.

[0027] Referring to **FIGS. 2 and 3**, the buffer layer **111** is formed on a top surface of the transparent substrate **100**, and then at least a TFT layer **200** is formed on a top surface of the buffer layer **111**. The TFT layer **200** can be formed by a typical method, and thus detailed description thereof will be omitted.

[0028] Referring to **FIG. 4**, after completion of the TFT layer **200**, the third insulation layer **129** is formed on a top surface of the TFT layer **200**. The first electrode **112**, to which a potential is selectively applied through the TFT

layer **200**, and the bus electrode **150**, which is electrically insulated from the first electrode **112**, are formed on a top surface of the third insulation layer **129**. Here, the first electrode **112** and the bus electrode **150** are formed by bringing an evaporation mask (not shown), which has a pattern for the first electrode **112** and a pattern for the bus electrode **150**, into close contact with the third insulation layer **129** and evaporating a material for the first electrode **112** and a material for the bus electrode **150**. Since the first electrode **112** and the bus electrode **150** can be made of the same material, they can be simultaneously formed through evaporation. The formation of the first electrode **112** and the bus electrode **150** is not restricted to the above-described embodiment, but any method enabling the first electrode **112** and the bus electrode **150** to be formed simultaneously can be used.

[0029] As shown in FIGS. 5 and 6, the planarization layer **130**, i.e., the fourth insulation layer, having the first and second openings **131** and **132** at positions respectively corresponding to the first electrode **112** and the bus electrode **150**, are formed on the third insulation layer **129**. The organic layer **160** is formed on a top surface of the first electrode **112**.

[0030] As shown in FIG. 7, the second electrode **170** is formed in a predetermined pattern on a top surface of the planarization layer **130** and a top surface of the organic layer **160** to be electrically connected to the bus electrode **150**. The second electrode **170** is formed by bringing a mask having the pattern of the second electrode into close contact with the planarization layer **130** having the first and second openings **131** and **132** and performing evaporation.

[0031] As described above, line resistance, which increases with an increase in the size of an organic electroluminescent display, is reduced, where a bus electrode electrically connected to a second electrode is formed on a top surface of an insulation layer having a first electrode, thereby accomplishing uniform brightness of an image.

[0032] Although a few embodiments of the present invention have been shown and described, it will be appreciated by those skilled in the art that changes may be made in these elements without departing from the principles and spirit of the invention, the scope of which is defined in the appended claims and their equivalents.

What is claimed is:

1. An organic electroluminescent display comprising:
  - a substrate;
  - at least a thin-film transistor, which is formed on the substrate;
  - at least an insulation layer, which cover the thin-film transistor;

first electrodes, which are formed in a predetermined pattern on a top surface of the insulation layer and to which a voltage is selectively applied through the thin-film transistor;

bus electrodes, which are insulated from the first electrodes;

a planarization layer, which is an insulation layer and has openings exposing the first electrodes and the bus electrodes;

organic layers, which are formed on a top surface of the first electrodes; and

second electrodes, which are formed on a top surface of the organic layer and a top surface of the planarization layer and are electrically connected to the bus electrodes.

2. The organic electroluminescent display of claim 1, wherein the second electrodes are made of a transparent material.

3. The organic electroluminescent display of claim 1, wherein the first electrodes and the bus electrodes are made of the same material.

4. The organic electroluminescent display of claim 3, wherein the first electrodes and the bus electrodes are made of metal.

5. The organic electroluminescent display of claim 1, wherein the bus electrodes are formed on a top surface of the insulation layer.

6. The organic electroluminescent display of claim 1, wherein light emitted from the organic layers is discharged in a direction of the second electrodes.

7. A method of manufacturing an organic electroluminescent display, the method comprising:

forming at least a thin-film transistor on a top surface of a substrate;

forming at least an insulation layer on a top surface of the thin-film transistor;

forming first electrodes, to which a potential is selectively applied through the thin-film transistor, and bus electrodes, which are electrically insulated from the first electrodes on a top surface of the insulation layer;

forming a planarization layer on a top surface of the insulation layer to have openings at positions corresponding to the first electrodes and the bus electrodes;

forming organic layers on a top surface of the first electrodes; and

forming second electrodes on a top surface of the planarization layer and a top surface of selected organic layers and are electrically connected to the bus electrodes.

\* \* \* \* \*

专利名称(译)	有机电致发光显示器及其制造方法		
公开(公告)号	<a href="#">US20050194890A1</a>	公开(公告)日	2005-09-08
申请号	US11/116219	申请日	2005-04-28
申请(专利权)人(译)	三星SDI CO. , LTD.		
当前申请(专利权)人(译)	三星DISPLAY CO. , LTD.		
[标]发明人	KOO JAE BON PARK SANG IL		
发明人	KOO, JAE-BON PARK, SANG-IL		
IPC分类号	H01L27/32 H01L51/50 H05B33/10 H05B33/22 H05B33/26 H05B33/00 H01J9/00 H05B33/14		
CPC分类号	H01L27/3244 H01L27/3246 H05B33/26 H01L51/5228 H01L51/56 H01L51/5221		
优先权	1020020057336 2002-09-19 KR		
其他公开文献	US7034455		
外部链接	<a href="#">Espacenet</a> <a href="#">USPTO</a>		

摘要(译)

提供一种有机电致发光显示器及其制造方法。有机电致发光显示器包括基板，至少一个薄膜晶体管，其形成在基板上，至少一个绝缘层，其覆盖薄膜晶体管，第一电极，其在顶部以预定图案形成绝缘层的表面并且通过薄膜晶体管选择性地施加电压，与第一电极绝缘的总线电极，平坦化层，其是绝缘层并具有暴露第一电极和总线的开口电极，形成在第一电极的顶表面上的有机层，以及形成在有机层的顶表面和平坦化层的顶表面上并且电连接到汇流电极的第二电极。

